

City Council Questions

November 13, 2018 Council Meeting

ITEM 3.1 TERRA BELLA VISIONING AND GUIDING PRINCIPLES PLAN- VISION AND GUIDING PRINCIPLES

1. What is the plan for our recycling center?
2. Did we look at adding any streets, as we are proposing in East Whisman?
3. Have we discussed with the Elementary School District whether they have an interest in increasing the Crittenden Middle School footprint?
4. This may be premature, but do we have plans to improve transit stops along Shoreline Blvd.?
5. At the second workshop, there was a map showing a potential bike tunnel connecting this area to the Stevens Creek Trail? Is that a serious possibility?
6. How much area is zoned GI, MM, and ML, in the city?
7. How much area is zoned GL, MM, and ML in the Terra Bella area?
8. Has there been a study to determine what would be a good ratio of the following zoning areas, GL, MM, and ML for Mountain View?
9. How would the loss of the following zonings effect Mountain View GL, MM, and ML?
10. What specific examples of retail were mention for Shoreline?
11. What is meant by, Low-to moderate density, square footage, height, massing??
12. Open space, how much footage would be for open space?
13. What is the proposed transportation network for Terra Bella?
14. How would the dedicated single transit lane, effect traffic along Shoreline with all the new development?
15. At the workshops, was it asked, what geographical area did participate live?
16. With the workshops, was a no project option given?

17. Why at workshop 2, when shown versus option on residential building, why was one, two and three stories options not shown?
18. How many small businesses are located in Terra Bella area?
19. Why at workshop2, 2 – 3 office stories options not offered?
20. With limited access in to the Terra Bella East, with only Terra Bella Ave, Linda Vista Ave, and San Veron Ave. only road to this area, how are these streets going to be effect with traffic congestion?
21. What is the vacancy rate for Terra Bella?
Terra Bella vacancy rate is between 3.5-6%.
22. What is the office vacancy rate city-wide?
Office vacancy is 4.3% (the submarket is Mountain View and Los Altos)

ITEM 4.2 SHORT-TERM RENTAL ORDINANCE (SECOND READING)

1. I understand from a colleague in Sunnyvale that getting the contract with the rental platform vendor is proving to be difficult and time-consuming. Have you had a chance to start working on this contract yet? Do you have an estimate from them about how long it will take?

There are two agreements we will be pursuing in advance of July 1, 2019 registration deadline. A compliance vendor is a relatively straight forward agreement. The other is a voluntary collection agreement with Airbnb.

Staff has been reviewing VCAs between Airbnb and other cities (San Francisco, San Jose, and Palo Alto) to determine the components the City should include. Staff plans to contact Airbnb to discuss a VCA this week, following the 2nd reading of the ordinance. We do not have an estimate for the amount of time that an agreement with Airbnb will take, but expect to have it completed by July 1.

ITEM 4.3 PARKING AND TOW CODE AMENDMENTS (SECOND READING)

1. Can a parking enforcement person remove or cause a vehicle to be removed?
A police officer, community services officer, or a police assistant, may remove a vehicle from the roadway as prescribed in section SEC. 19.21 – Towing away of vehicles, which states the following:

Any regularly employed and salaried officer of the police department of the city may remove or cause to be removed:

- a. *Any vehicle that has been parked upon a street, highway or public parking lot for seventy-two (72) or more consecutive hours.*

- b. *Any vehicle obstructing the free flow of traffic on any street or in the traveling lane of any parking lot.*
- c. *Any vehicle that is parked after signs have been erected giving notice that the parking of vehicles upon such street or portion thereof is prohibited. Such signs shall be erected in the manner required by Vehicle Code Sec. 22651(l) and (m) and shall either be erected by or authorized to be erected by the city, including pursuant to an excavation or encroachment permit.*
- d. *Any vehicle that is parked where prohibited under the city code and signs are posted giving notice of the removal.*

The Police Assistants enforce the parking restrictions but they do not have authority to tow vehicles. The Police Assistants tow vehicles when accompanied by a CSO or an officer, as these individuals serve as towing officials for the City.

ITEM 4.4 FISCAL YEAR 2017-18 ANNUAL COMPLIANCE REPORT FOR DEVELOPMENT IMPACT FEES AND CAPACITY CHARGES; AND INFORMATIONAL REPORTING OF PARK LAND DEDICATION FEE

1. How the information was made available to the public on Oct 4?

The information was made available to the public on October 4th via the Council Agenda Packet for the October 9, 2018 Council Meeting Item 4.3.

ITEM 4.6 SOUTH WHISMAN PARK DESIGN, PROJECT 17-34-AUTHORIZE PROFESSIONAL SERVICES AGREEMENT

1. Will this park have a restroom?

A restroom for this 2.76-acre park will be considered during the design and community outreach process. Ultimately, the City Council will decide whether a restroom is included. Based on the City's current criteria (see below), staff anticipates that restrooms will be included to support athletic facilities.

2. What are the city's standard rules for whether a park has a restroom or not?

The current guidelines for providing restrooms (last reviewed by Council on October 25, 2016) include:

- *The park is a neighborhood or community park a minimum of three (3) acres in size.*
- *The park provides extended-stay activities such large BBQ areas, swimming, tennis, or athletic activities.*
- *If a park is jointly owned and/or operated, both parties must agree on the restroom(s).*
- *Restrooms meet design standards support of activity levels of the park.*

ITEM 6.1 PUBLIC HEARING ON DOWNTOWN BUSINESS IMPROVEMENT AREAS (BIAS) NO. 1 AND NO. 2 AND ALLOCATION OF 2019 BIA REVENUES

1. What caused the deficit, and was why was there business refunds?

The deficit in the Central Business Association's (CBA) operating budget was caused by a decrease in revenues from several events - Thursday Night Live beverage sales, Beer Walk and Wine Walk, and an increase in event expenses. The business refunds was created from an error in the Business Improvement Area (BIA) fee category. The BIA fees were collected by the City and were then transferred to the CBA before the error was discovered. The CBA in coordination with the City processed refunds for all 67 affected businesses.

2. Is there a Balance sheet?

Yes - the CBA has a budget in their Annual Report. (Attachment 3 of the Council Report - Page 12.)

ITEM 6.3 UPDATES TO THE GATEKEEPER PROCESS AND PUBLIC HEARING NOTICING REQUIREMENTS

1. Does noticing include tenants at the project site, and not just tenants at sites that are 500' or 750' from the project site?

Noticing does include tenants on site.

2. Please expand on why staff doesn't think 14 day notification is needed and that 4 extra days is too long?

Staff has received feedback for increasing the noticing time as well as keeping the current noticing timeline of 10 days. Some people believe that a longer noticing time increases the chances that the notice can be missed and/or the meeting forgotten about, whereas some people believe that 10 days is not long enough for people to arrange their schedules to attend the meeting. In staff's experience, 10-day noticing time provides adequate time for the public to be notified of up-coming meetings and Mountain's staff's ability to schedule projects in a timely matter.

3. On the exemptions for going from industrial to residential, was there any specific requirements in the new residential that would allow for exemptions? Does it have to be conforming?

The exemption is applicable if the adjoining property is zoned residential. If the adjoining property has a non-conforming residential development on a non-residential zoned parcel, it would not qualify for this exemption.

4. Why differentiate between 500 and 750 feet? Why not just go with one at 750?
The two noticing radii were proposed based on Council direction and discussion at the study sessions and public hearings. Council requested that staff amend the regulations to increase the minimum noticing requirement from 300' to 500' and increase the noticing radius for larger projects (greater than 2 acres) as these may have greater impacts to the surrounding neighborhood given the size of the project.

5. I didn't notice anything about the documentation for a Gatekeeper, was to be more detailed, is this something that can be addressed? On page 3 of the March 27 staff report, it mentions increasing the documentation.

The last round of Gatekeeper code amendments approved by Council in April 2018 included more detailed gatekeeper submittal requirements.

**ITEM 6.4 405 SAN ANTONIO ROAD - CONDITION OF APPROVAL NO. 42
(CAFETERIA CONDITION)**

1. How is compliance going to be verified?

The revised condition adds minimum requirements for annual reporting, which was not part of the original Cafeteria Condition. Pursuant to the revised condition, compliance will be verified through reports provided by the applicant to the City, for the first five years any Food Service Plan is in effect. It was anticipated this would allow sufficient time for a fully compliant plan to be in effect, based on growth in restaurant businesses in San Antonio Center. Council may modify the revised condition to include different reporting requirements if desired.

2. Why shouldn't compliance be done on an annual basis, with not sunset date?

Facebook has proposed to exceed this minimum requirement by providing quarterly reports during Phase 1 of their Plan, a summary report at the end of their first year of occupancy, and biannual (twice a year) reports thereafter (with no sunset date). Council could eliminate the 5 year sunset if so chooses.

3. What was thoughts behind having the ZA modify the conditions of approval and not the Council?

The standard process in the Zoning Code for a request to modify conditions of approval is through a ZA public hearing process. The thought was that Council action on the revised condition of approval and initial Food Service Plan would provide clear direction for any subsequent implementation of the Cafeteria Condition by the Community Development Director and Zoning Administrator through this standard process.

4. With Facebook having a 3 year lease and expected to move to Sunnyvale in the near future, would that have any effect on the conditions of approval and would the condition anticipate future tenants?

The revised condition of approval is not affected by Facebook's lease term; the revised language is intended to provide clear criteria for compliance by any future tenant.

5. For the purpose of this condition, what are the boundaries of the San Antonio Center?

San Antonio Center includes the parcels bounded by El Camino Real, San Antonio Road, California Street and Showers Drive.

6. How will the condition be enforced?

The revised condition identifies a minimum requirement for annual monitoring, with full compliance expected unless San Antonio Center restaurants do not have adequate meal capacity. The condition does not include any penalty or enforcement structure beyond this monitoring requirement.

The Zoning Code provides a few avenues for enforcement. Although rarely utilized, the Zoning Code allows the Zoning Administrator to revoke or modify any permit or entitlement through a duly noticed public hearing for non-compliance with project conditions. The Zoning Code also enables code enforcement penalties and other civil enforcement procedures.

ITEM 8.1 EVANDALE AVENUE MINI-PARK, PROJECT 17-45-APPROVE CONCEPTUAL PLAN AND SELECT NAME FOR PARK

1. What is the estimated tree canopy coverage in the play area, and in the plaza area, separately?

At full size, the canopy over the plaza area is designed to be about 80%-85% coverage. For the play area, the trees on the east side will provide morning shade (15% of the playground), and those on the west side will provide afternoon shade (10% of the playground). The street trees on the south side will also provide some shade. With required fall zones around play equipment, providing tree canopy shade over the equipment is more challenging than other areas, such as the plaza.

2. What is meant by “modern” style for furnishings and play equipment? How is staff interpreting this?

A “modern” style was one of the requests from the community. While specific furniture models have not yet been selected, staff interprets that as sleek, clean lines or with a modern aesthetic. Some possible examples are shown below. Staff will also be looking for durable materials to reduce maintenance and replacement costs.

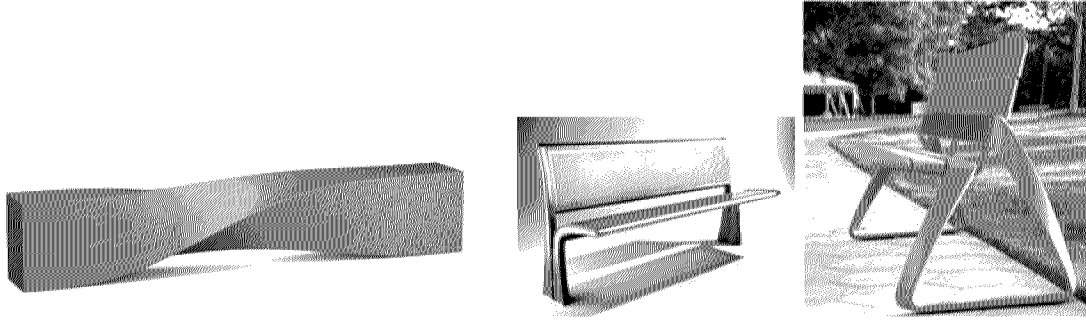

3. Is it possible to have the benches and picnic tables unique and artsy?
Yes, though this will generally add cost.

4. Are artsy benches and picnic tables more expensive? If so, about how much?
Typically, benches from commercial suppliers (either traditional or modern) that are designed for heavy park use range from \$1000 - \$2500 each. Custom benches specifically designed and manufactured for this project, based on the experience of our designer, could cost as much as \$14,000.

If Council has direction on the style of the park furniture, staff can consider that direction while selecting furniture for the project.

5. Can more trees be added in the play area to provide some shade?
Adding trees within the play area is challenging, as fall zones are required around the play equipment and some distance must be maintained between trees and the rubberized play surface. Based on Council's direction this evening, the design team can maximize canopy shade in the play area with the play area and equipment shown in the recommended concept.

6. What ages of children are expected to use to the play equipment?
The community requested play equipment designated for the 5-12 age range. A few of the standalone items will be appropriate for the younger 2-5 range.

**ITEM 8.2 WYANDOTTE STREET PARK, PROJECT 17-40-APPROVE
CONCEPTUAL PLAN AND RELATED ACTIONS**

1. Will there be a restroom in the park?

No restroom is included because the park is only 0.88 acres and there are no extended-stay activities anticipated.

2. What are the benefits of a mounded lawn?

The mounded lawn area was requested by the community and merely provides topographic interest to the site.

3. Was aspects for older person consider for this park? Basketball Par course?

There was not a specific discussion about elements for older park users at the community meetings.

4. Any thought to incorporating Ecological learning opportunities?

If Council desires staff can look into some specific signage highlighting the trees in the area etc. on an informational sign in the designated park space area, like signs at Mariposa Park. No input or requests on this came from the residents at the Community Meetings.