

On the Hunt Bronze Statue

Item #: BMJ51818

Size: 33" H. x 22" W. x 18" D.

Quality, attention to detail and experience does make a difference. All of our statues are 100% bronze and cast by hand in the Lost Wax process. Call us today at (888) 972-7230 for more information about our bronze eagle statues.



-	
Call to Order Today	View All Items

APPROVED BY _____

DATE _____

ITEM	QTY.	PART NUMBER	DESCRIPTION	MATERIAL
1	2	CSTM-10020-1	CANTILEVER ALUMINUM PEDESTAL	ALUMINUM
2	1	CSTM-10020-2	BRONZE EAGLE STAND	
3	1	CSTM-10020-MOCKPNL	MOCK PANEL	LAMINATE
4	4	.25-20X.75BHSCS	1/4-20X.75 BUTTON HEAD SCREW	18-8 SS

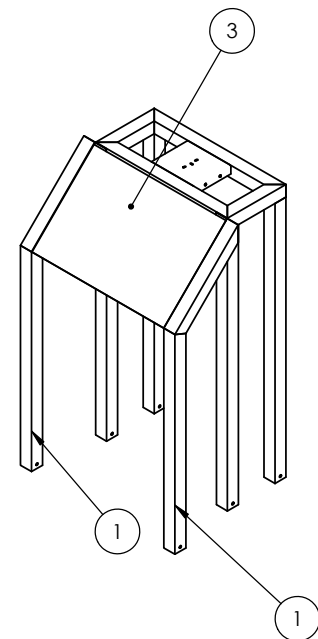
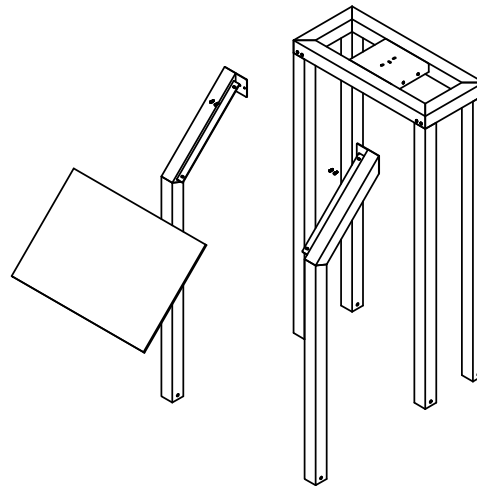
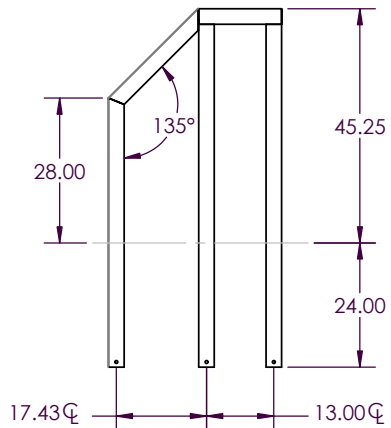
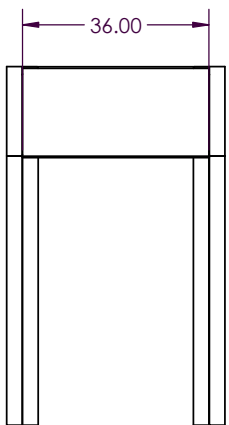
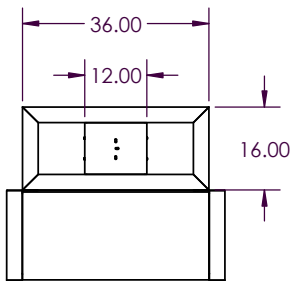

FINISH BLACK TEX POWDER COAT

PROPRIETARY AND CONFIDENTIAL

THE INFORMATION CONTAINED IN THIS DRAWING IS THE SOLE PROPERTY OF Envirosigns EXHIBITS. ANY REPRODUCTION IN PART OR AS A WHOLE WITHOUT THE WRITTEN PERMISSION OF Envirosigns EXHIBITS IS PROHIBITED.

<p>UNLESS OTHERWISE SPECIFIED</p> <p>-DIMENSIONS ARE IN INCHES</p> <p>-DIMENSIONAL TOLERANCES</p> <p>FRACTIONAL ± 1/32</p> <p>ANGULAR: MACH ±.5°/BEND ±1°</p> <p>TWO PLACE DECIMAL ±.030</p> <p>THREE PLACE DECIMAL ±.010</p>	NAME	DATE	<p>TITLE:</p> <p>BRONZE EAGLE STAND ASSEMBLY</p>	
	DRAWN	KPD		4/12/2023
	LAST SAVE	kdofson		4/21/2023
	MATERIAL:			
	SEE BOM			
PROJECTION:	DWG. NO.		REV	
	CSTM-10020-ASM		SIZE	
			B	
DO NOT SCALE DRAWING	SCALE: 1:24	WEIGHT: 87.021	SHEET 1 OF 2	

8 7 6 5 4 3 2 1